

61.6 ft

Medium Chirp

IN-HULL

Auto G
39 C

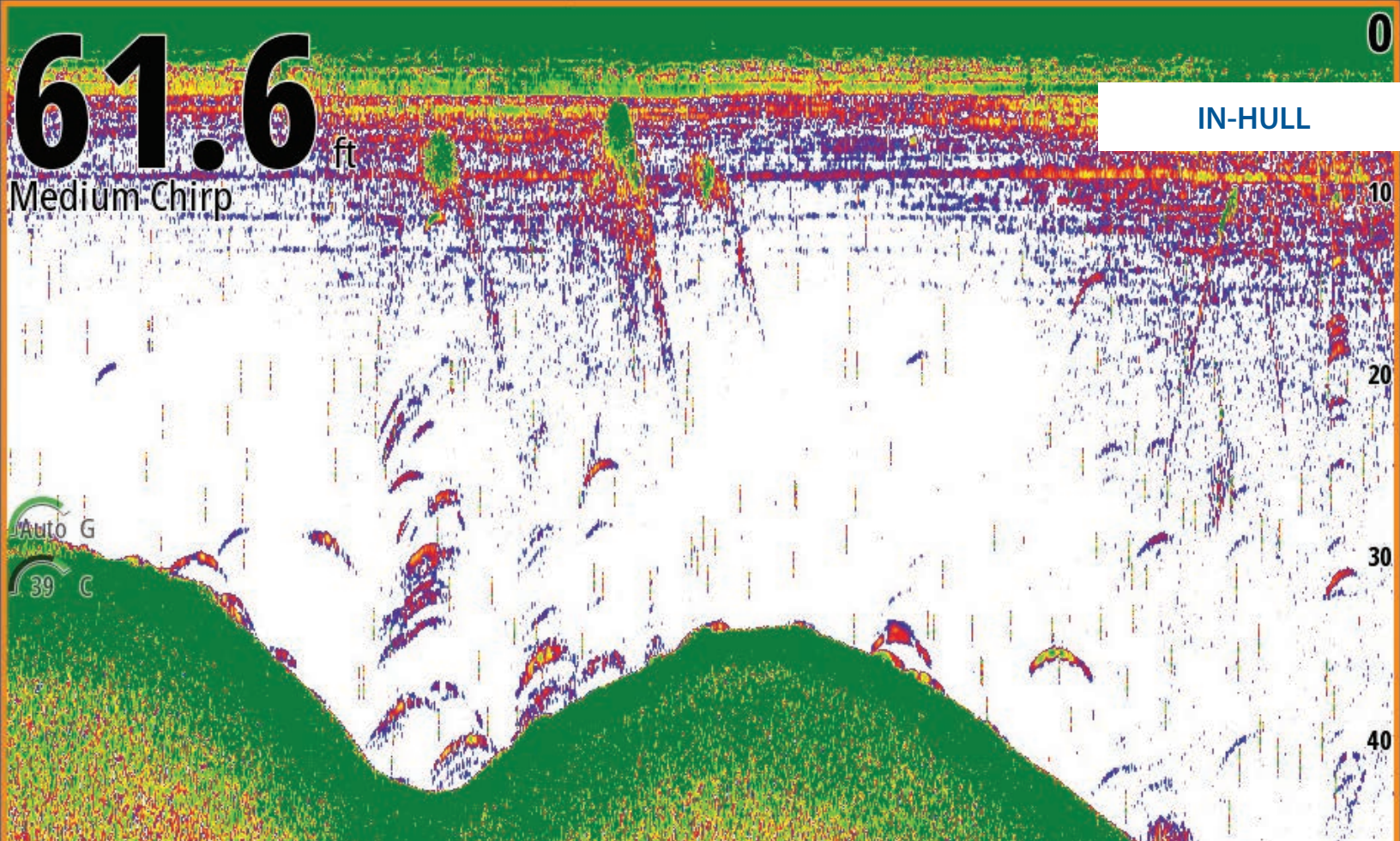

P75M screenshot courtesy of Navico

In-Hull Chirp Transducers

As Chirp technology remains at the forefront of echo sounder development, Airmar continues to add transducers for every installation type.

When performance matters most, we've got you covered.

The Benefits of Airmar's Chirp-ready Transducers

- One broadband transducer covers up to 117 kHz of bandwidth – greater opportunities to detect fish in the water column
- Superior resolution – precise separation between baitfish and gamefish represented on the display with crisp images
- Enhanced bottom fishing – resolve targets close to the bottom or near structure/wrecks
- Amazing detail – recognize haloclines and thermoclines
- Improved signal to noise ratio – find fish and track bottom at high boat speeds



AIRMAR® ...IT'S WHAT'S UNDER YOUR BOAT.

 **AIRMAR®**
TECHNOLOGY CORPORATION

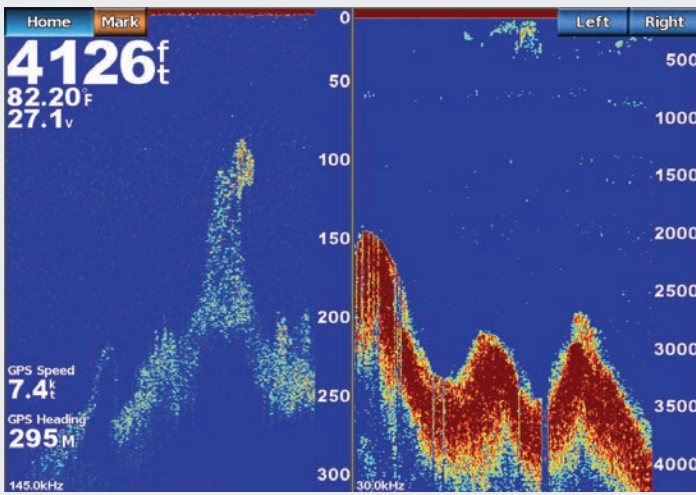

Courtesy of Garmin

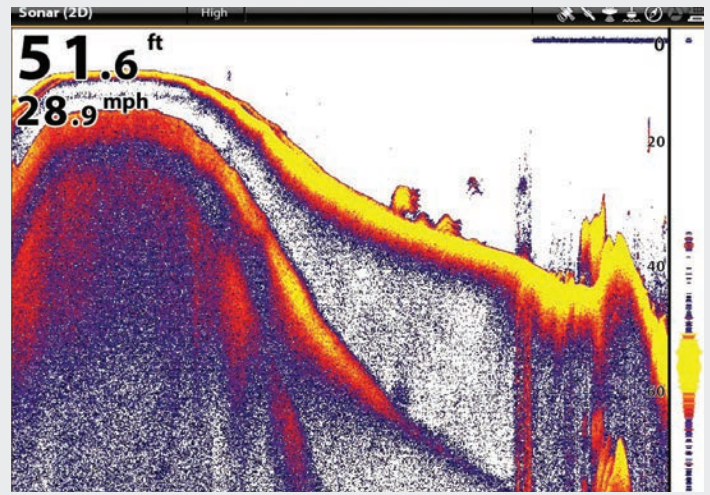

Courtesy of Humminbird



Benefits of In-Hull Transducers

In-Hull transducers are installed inside the boat hull. The transducer is suspended in a liquid filled tank and transmits its sonar directly through a solid fiberglass hull. Some prefer this mounting style because it is not necessary to drill through the vessel's hull and it can be installed and serviced while the vessel is in the water. The transducer cannot be damaged by debris, hauling or trailering. The transducer is not exposed to marine growth, and there is no drag. And, the wide frequency band of a Chirp transducer allows you to select the best frequency for your hull's thickness.

Advantages

- No hull penetration (no holes in the hull)
- Installation and service can be performed while the boat is in the water
- No exposure to marine growth; no drag
- Ideal for trailered boats

The best fishing stories begin with the right transducer.

Why does frequency matter?

Selecting the best frequency for your specific application is very important. The good news is that once you know what frequency will work best for the type of fishing you do, there's an AIRMAR transducer designed to maximize the performance of your sounder.

AIRMAR Chirp transducers are available in various frequency combinations:

- Dual Band:
 - Low/High (LH)
 - Low/Medium (LM)
 - Low/High Wide (LHW)
 - Low Wide/Medium (LWM)
- Single Band:
 - Low
 - Medium
 - High
 - High wide

Low Frequency = Greater Depth (ex. 42-65 kHz)

- Sound waves will not present as clear a picture of the bottom on the display, but will sound down in very deep areas where high frequency sound waves cannot reach
- Provides greater depth range, wider beamwidth, and ultimately more coverage under the boat
- Chirp signal processing technology used with Airmar broadband, Chirp-ready transducers provides more detail at greater depths and is less susceptible to noise
- Great for operating at high boat speeds

High Frequency = Greater Detail (ex. 130-210 kHz)

- More sensitive to small targets and will send back detailed information which will display as crisp, high-resolution images on the echosounder screen
- Best for shallower water and popular with anglers fishing at depths less than 1500 feet

Medium Frequency = The Best of Both Worlds (ex. 80-130 kHz)

- Provides the ability to sound deeper than the high frequency, along with better resolution than the low frequency
- Wider beam than the high frequency, achieving more coverage under the boat and greater opportunity to find fish
- Clear images at higher boat speeds

In-Hull

1 kW

Features:

- Depth only
- Hull Type: Solid fiberglass stepped, planing or displacement hull types
- Plastic / Urethane transducer housing
- Hull deadrise: Up to 30°
- Engine type: Can be used with single or twin inboard, I/O, OB and jet drive propulsion

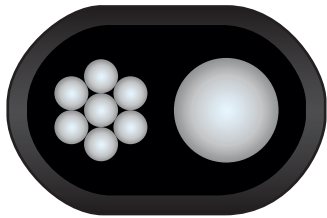

8-Internal
Broadband Ceramic
Assemblies

DIMENSIONS

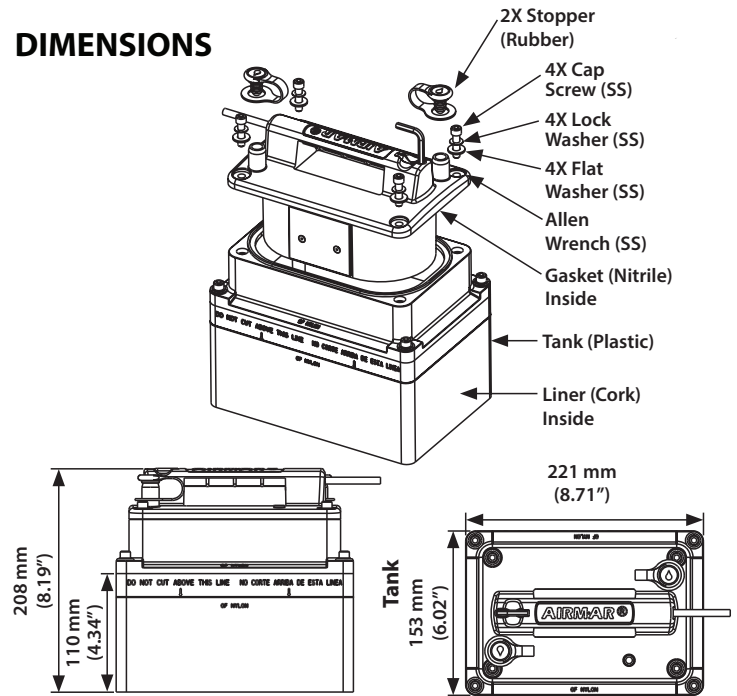

M265LH

Low & High Frequency

MSRP \$1,685.00

- Low—42 kHz to 65 kHz
25° to 16° beamwidth
Maximum depth 3000 ft
- High—130 kHz to 210 kHz
10° to 6° beamwidth
Maximum depth 1000 ft
- 103 kHz of total bandwidth from one transducer

Bottom Coverage Relative to Frequency and Depth

Depth	Beam Coverage at High Frequency	
	M265LH 130 kHz-210 kHz	
50 ft	8 ft	
100 ft	18 ft	
300 ft	58 ft	
600 ft	104 ft	
1000 ft	174 ft	
1500 ft	Too Deep	

This chart compares the high ceramic element inside the transducer, showing the difference in bottom coverage under the boat.

The low frequency in this model sounds to 3,000 ft.

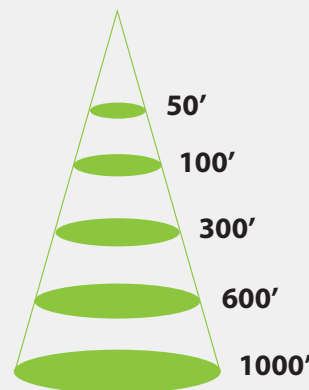

M265LH – High Frequency
130 kHz-210 kHz

The fish must be in the beam to be represented on the display.

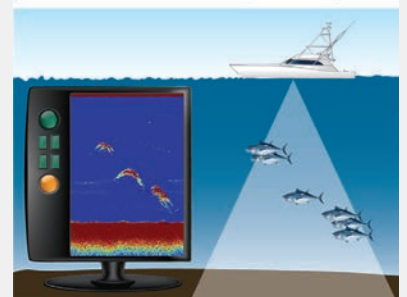
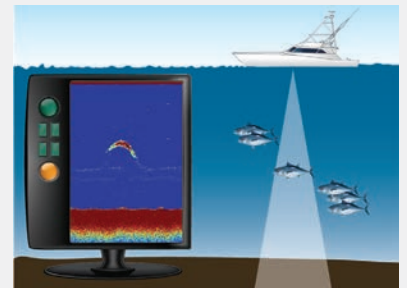

In-Hull

2 kW

Features:

- Depth only
- Hull Type: Solid fiberglass stepped, planing or displacement hull types
- Plastic / Urethane transducer housing
- Hull deadrise: Up to 30°
- Engine type: Can be used with single or twin inboard, I/O, OB and jet drive propulsion

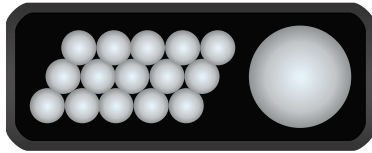

16-Internal
Broadband Ceramic
Assemblies

DIMENSIONS

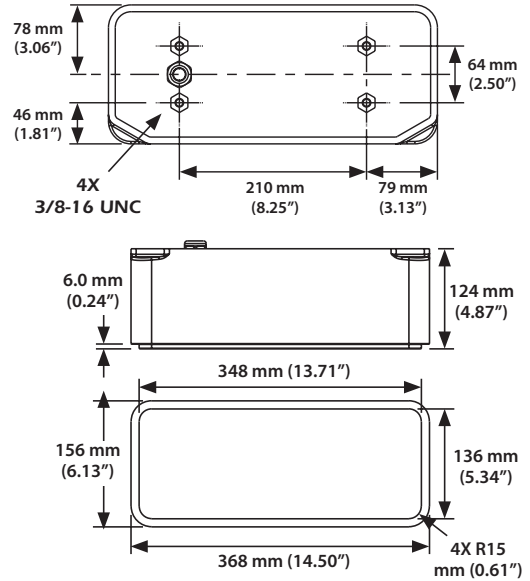

R111LH

Low & High Frequency

MSRP \$3,585.00

- Low—38 kHz to 75 kHz
 19° to 10° port-starboard
 10° to 5° fore-aft beamwidth
 Maximum depth 6000 ft
- High—130 kHz to 210 kHz
 8° to 4° beamwidth
 Maximum depth 1500 ft
- 117 kHz of total bandwidth from one transducer

R111LM

Low & Medium Frequency

MSRP \$3,910.00

- Low—38 kHz to 75 kHz
 19° to 10° port-starboard
 10° to 5° fore-aft beamwidth
 Maximum depth 6000 ft
- Medium—80 kHz to 130 kHz
 13° to 8° beamwidth
 Maximum depth 3000 ft
- 87 kHz of total bandwidth from one transducer

Bottom Coverage

Relative to Frequency and Depth

Depth	Beam Coverage at High Frequency	
	R111LH 130 kHz-210 kHz	R111LM 80 kHz-130 kHz
50 ft	6 ft	10 ft
100 ft	14 ft	22 ft
300 ft	42 ft	68 ft
600 ft	84 ft	136 ft
1000 ft	140 ft	228 ft
1500 ft	210 ft	342 ft
2000 ft	Too Deep	456 ft

This chart compares the high and medium ceramic elements inside the transducer, showing the difference in bottom coverage under the boat.

Low frequency in each of these transducer models is the same (38-75 kHz). This low frequency can range to 6,000 ft.

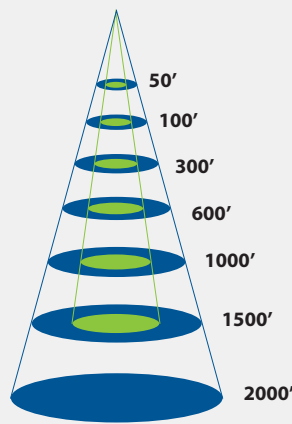

■ R111LH – High Frequency
 130 kHz-210 kHz
■ R111LM – Medium Frequency
 80 kHz-130 kHz

The fish must be in the beam to be represented on the display.

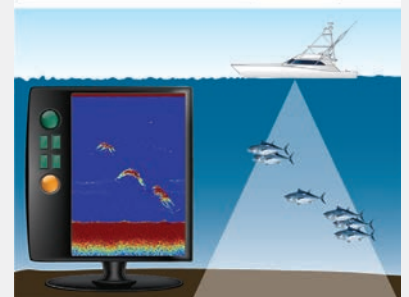
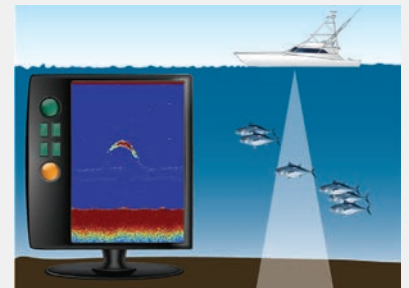

In-Hull

2-3 kW

Features:

- Depth only
- Hull Type: Solid fiberglass stepped, planing or displacement hull types
- Plastic / Urethane transducer housing
- Hull deadrise: Up to 30°
- Engine type: Can be used with single or twin inboard, I/O, OB and jet drive propulsion

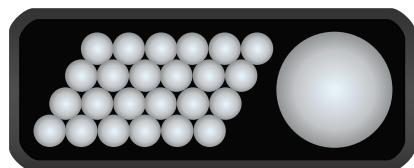

25-Internal
Broadband Ceramic
Assemblies

DIMENSIONS

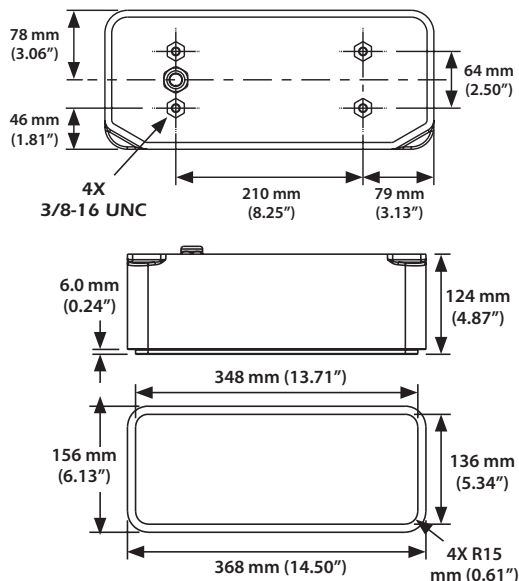

R599LH

Low & High Frequency

MSRP \$4,975.00

- Low—28 kHz to 60 kHz
 23° to 9° port-starboard
 11° to 5° fore-aft beamwidth
 Maximum depth 10000 ft
- High—130 kHz to 210 kHz
 8° to 4° beamwidth
 Maximum depth 1500 ft
- 112 kHz of total bandwidth from one transducer

R599LM

Low & Medium Frequency

MSRP \$5,310.00

- Low—28 kHz to 60 kHz
 23° to 9° port-starboard
 11° to 5° fore-aft beamwidth
 Maximum depth 10000 ft
- Medium—80 kHz to 130 kHz
 13° to 8° beamwidth
 Maximum depth 3000 ft
- 82 kHz of total bandwidth from one transducer

Bottom Coverage

Relative to Frequency and Depth

Depth	Beam Coverage at High Frequency	
	R599LH 130 kHz-210 kHz	R599LM 80 kHz-130 kHz
50 ft	6 ft	12 ft
100 ft	14 ft	24 ft
300 ft	42 ft	68 ft
600 ft	84 ft	136 ft
1000 ft	140 ft	228 ft
1500 ft	210 ft	342 ft
2000 ft	Too Deep	456 ft

This chart compares the high and medium ceramic elements inside the transducer, showing the difference in bottom coverage under the boat.

Low-frequency in each of these transducer models are the same (28 kHz - 60 kHz).

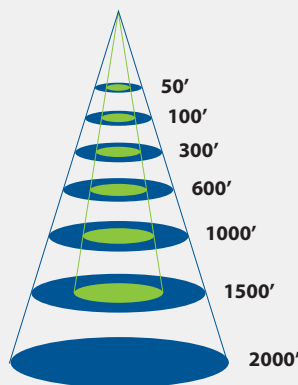

■ R599LH – High Frequency
 130 kHz-210 kHz
■ R599LM – Medium Frequency
 80 kHz-130 kHz

The fish must be in the beam to be represented on the display.

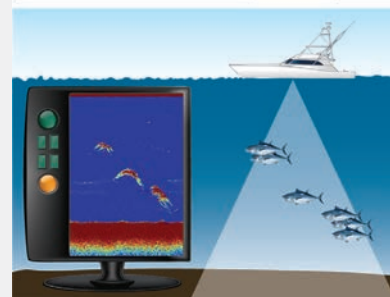
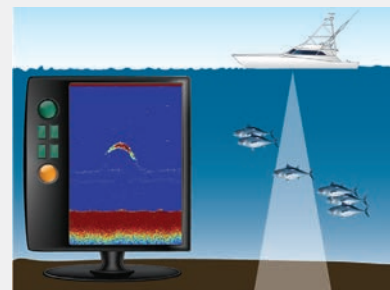

The Chirp Advantage

Traditional sounders operate at only two discrete frequencies – typically 50 kHz and 200 kHz. This results in limited depth range, resolution, and ultimately what targets can be detected in the water column.

In contrast, Airmar’s game-changing CHIRP-ready transducers provide over 70+ kHz of bandwidth. Transmitting over a wide frequency band results in a greater opportunity to detect what is in the water column. As a result, all targets detected in the entire bandwidth will be seen on the display—even those fish holding close to the bottom—ultimately improving target detection, detail, and range resolution.

Most CHIRP transducers vary their beam width as they sweep through their frequency range (low, medium, and high). At the lowest frequency the beam is the widest and it narrows as the frequency increases.

Airmar’s new wide beam CHIRP transducers are the exception to this rule and have a fixed beam width of either 25° or 40° across the frequency band. This translates into even more coverage under the boat, revealing more fish in the water column than ever before.

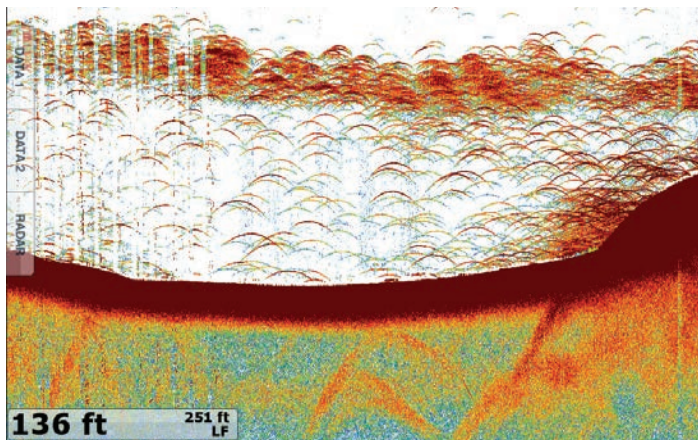

Courtesy of Furuno

Additional Mounting Options

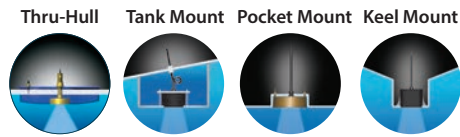

Choosing your mounting option depends on the design of the hull as well as the material it’s manufactured with, the boats intended use, and the desired level of performance.

Need Help Choosing the Right Transducer?

Download the free, award-winning **iNstall app!** It’s a great tool that takes the guesswork out of selecting the right transducer for your application. Based on frequency, mounting, housing, and cable options, iNstall will reveal the available option(s) and give you instant access to their specifications. Designed for iPhone, iPad and iPod smart phones and tablets running iOS 6.1 and newer.



iNstall

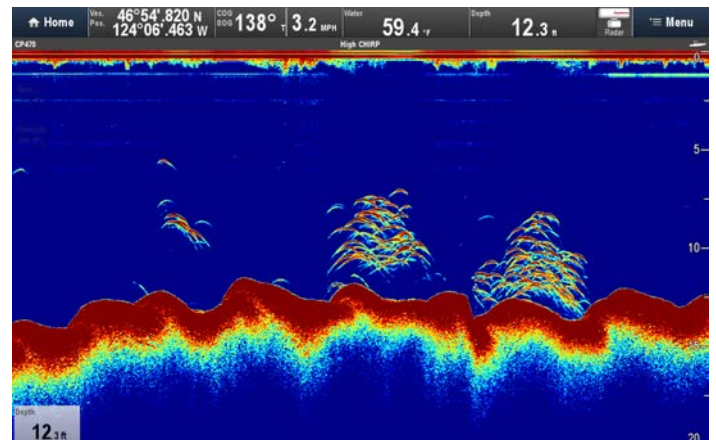

Courtesy of Raymarine



www.airmar.com

©Airmar Technology Corporation

In-Hull Chirp_BR2017_RB 05/26/17

As Airmar constantly improves its products, all specifications are subject to change without notice. All Airmar products are designed to provide high levels of accuracy and reliability, however they should only be used as aids to navigation and not as a replacement for traditional navigation aids and techniques. Xducer ID® is a registered trademark of Airmar Technology Corporation. Other company or product names mentioned in this document may be trademarks or registered trademarks of their respective companies, which are not affiliated with Airmar.